

[info@garantia.de](mailto:info@garantia.de)  
[www.garantia.eu](http://www.garantia.eu)



## User information

### *water back-up supply*

We congratulate you on the purchase of our fill level measuring device. You have purchased a high-quality product built to the highest standards of modern technology. Before you start to assemble or operate the equipment, please read the user information with care and check exactly the parts supply for completeness.

List of parts supplied:

1. The fill level indicator.
2. The wall power supply.
3. The stainless steel measurement probe (red and white connection cables approx. 3 m long).
4. The 20 m long data cable.
5. The Measurement sensor.
6. The valve with pipe back flow preventer
7. Installation material

#### **Important notes on safety:**

**Please, read and follow safety instructions carefully before assembly or using the device!**

The assembly place must allow all possible safety precautions when laying the attached cables. Power supply cables and data cables may not be damaged or squeezed for any reasons. Plan the assembly place so that you can reach the wall power supply easily and unplug it from the electrical outlet in dangerous situations. Choose the assembly place so that children cannot play or be near to the device and at its connections without supervision. At chosen intervals in this hand book we will give directions for safety precautions. These safety precautions have been specially marked.

**Otto Graf GmbH**  
**Synthetic products**

**Carl- Zeiss Str. 2-6**  
**D 79 331 Teningen**

**tel.: +49 (0) 7641 5890**  
**fax: +49 (0) 7641 58950**

## 1. Description of the equipment

The Fill level indicator has been developed especially for rain water usage. Synthetic material tanks are used. Cement and metal tanks are only conditionally usable. With the calibration function the system is coordinated to the different tank heights. The fill level in the tank is shown in 1% steps by a 3-digit LCD-display. The sensor electronics work with a 12 volt of low current and is reverse polarity protected; it is attached to the main device with a 20 m long data cable. As soon as the calibration and the assembly are completed no further setting up is necessary. The reference value for a 100% fill level remains stored in the case of a power failure.

Performance features:

- Fill level indicator in 1% steps
- Status LED which shows the operation in progress
- Self calibrating routine
- Permanent supervision of sensor electronics
- Error messages in the error code

The following picture shows your newly acquired device:

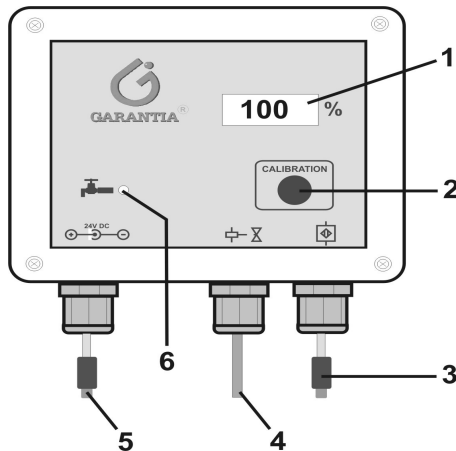

- 1: LCD- display
- 2: Button for setting the maximum filling level coordination
- 3: Connector for the data cable
- 4: Connector for the valve
- 5: Connector for the power supply
- 6: LED – back-up supply with mains water is **ON**

**Figure 1: Overall equipment list**

## Technical data:

### Water back-up supply

Operating voltage : 24 volts =  
Power consumption : 0,8 watts

### Sensor electronics

Measuring current : 12 volts =  
Measuring frequency : 200Hz -20KHz  
Cable length : maximum 50m  
Tank depth : maximum 3m

Measurements (LxWxD):  
120 x 79 x 59 mm with protection  
to : IP 54

Measurements (LxWxD):  
90 x 80 x 50 mm with protection  
to : IP 54

### Valve connection

Operating voltage : 24 volts =  
Current : maximum 1A

### Wall power supply

Operating voltage : 100V AC bis 240V AC  
Frequency : 50Hz bis 60Hz  
Output current : 1A  
Protection class : II (protective insulation)

### Switching points:

**Valve On : 10%**  
**Valve Off : 12%**

## 2. Assembly :

### 2.1.1 Drinking water – refill valve:

For the installation of the mains water refill it is very important to ensure that there is no connection between the mains water supply (drinking water) and the domestic process water supply system. Under no circumstances should a reaction between the domestic process water supply system and the municipal mains water supply occur. For this reason, the supplied refill valve is coupled with the pipe interruption device already installed. This prevents a back suction. **The position of installation must be higher than the highest possible water level in the rain water tank including the overflow.**

At the other end of the installed device an NW50 pipe (not supplied) is connected to the black plastic section and then routed into the tank. Connect now the electrical cable with the prepared plug connection to the solenoid valve. Tighten the threaded part firmly to the seal.

*Please note: During operation the solenoid valve will become warm.*

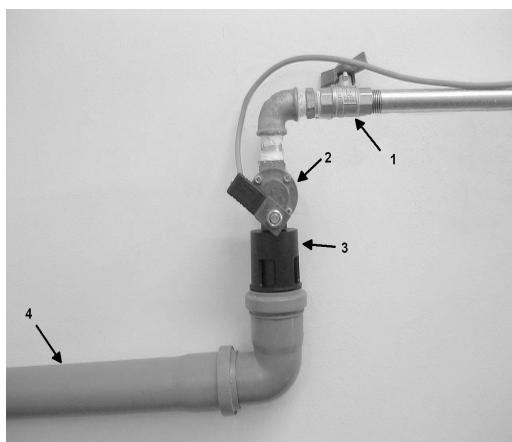

- 1: Shut-off valve
- 2: Solenoid valve
- 3: Pipe back flow preventer
- 4: Refill pipe to tank

*Figure 2: Installation example of pipe back flow preventer*

### **2.1.2. General installation and assembly regulations:**

It is necessary to the instructions when installing a rain water usage equipment:

EN 806:

- Drinking water installation
- Planning and implementation
- Calculation of the pipe diameters
- Using the equipment

EN 1717:

- free outlet between drinking and rainwater
- Notification sign to inform that a rainwater usage system is installed in the locality
- Notification signs marking the rainwater outlets
- Notification signs marking the rainwater installations network
- Backflow prevention (e.g. a non-return/check vale)

- Frost free installation
- Reservoir/tank with air bleeding/ventilation
- No diameter reduction in the drainage system according to EN 1256
- Technical regulations in relation to groundwater drainage according to EN 752
- Drainage systems outside of buildings according to the regulations of the local service authorities
- *When required : Obligatory registrations of the system and other mandatory stipulations.*

Figure 3 shows an example installation (not to scale):

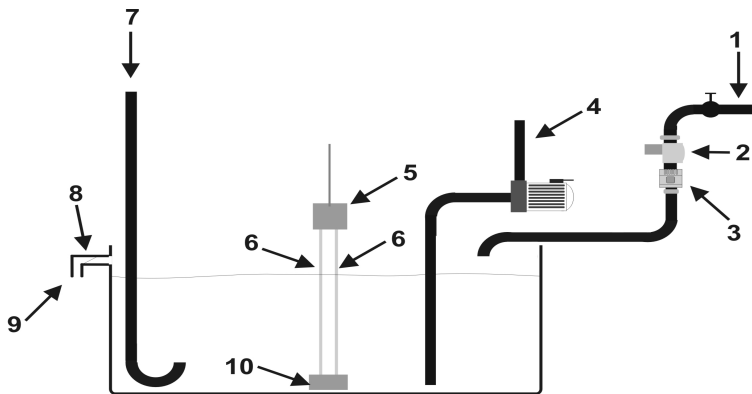

- |                             |                                |
|-----------------------------|--------------------------------|
| 1: Mains water              | 6: Sensor cable                |
| 2: Solenoid valve           | 7: Rain water inlet pipe       |
| 3: Pipe back flow preventer | 8: Back water gate             |
| 4: Domestic process water   | 9: To waste water canalisation |
| 5: measurement pick-up      | 10: Stainless steel weight     |

*Figure 3: Sketch of a possible installation example*

## **2.2. Housing the control electronic:**

The assembly of the control electronic must be closed to the mains electrical supply socket. To fasten the top two mounting holes in the case are sufficient.

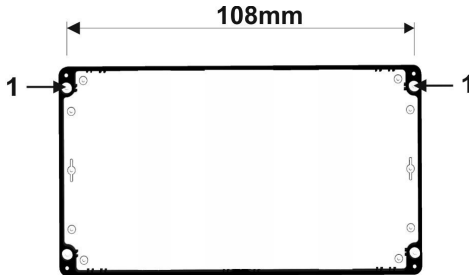
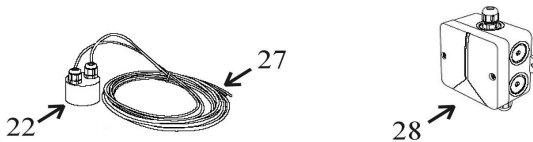

*Figure 4: Mounting holes*

Mark out the hole positions at a distance of 108mm on the selected wall position and drill accordingly. Please use the enclosed mounting materials (dowel plugs and screws). Before mounting the unit you must first open the cover. To do this, loosen the 4 screws visible from the front, flip the cover upwards and hold securely in position. Insert the screws into the mounting holes of the housing (**1**) in illustration 4) and screw the unit securely to the wall. Now reclose the cover and screw firmly into place.

## **2.3. Connection sensors and data cable:**

The sensor electronics comprise of a stainless steel probe **[22]** with a red and a white connecting cable **[27]** and the sensor measurement pick-up **[28]**.



*Figure 5: Sensor technology*

1. Now the sensor measurement pick-up [28] (cover removed) should be installed on the tank wall (preferably in the man hole shaft of the Graf synthetic tank). The location of the mounted sensor pick-up should be between 10 and 15 cm above the overflow [25]. The enclosed screws should be used to secure the device. After fully tightening the screws, the points that are showing themselves on the outside of the tank must be blunted to avoid injury [24].
2. Measure the height from the bottom of the tank [23] to the end of the terminals [15] and [16] on the measurement pick-up [28].
3. Shorten the connection cable to suit the measured height.
4. Connect the sensor cable to the sensor as described in the following instructions: Remove between 5-7 mm of the insulation from both of the cables. Next, pass the red cable through the screw mounting 1 [19] and tighten this lightly, then connect the red cable to the terminal [16]. The free white cable is now passed through the screw mounting 2 [18] and tightened lightly, then connect the white cable to the terminal [15].
5. Now pass the end of the data cable that has no plug connector [12] through the screw mounting [13]. Lightly tighten the screw mounting and connect the cable wire cores of the data cable [12] to the double terminal [14]. The connection of the data cable is reverse polarity protected. **Attention! The screws should be tightened with care to ensure that they are not damaged through over tightening.**
6. Now recheck that all the screwed items and the sensor components have been fitted correctly. Replace the cover of the measurement pick-up and secure this with the appropriate fastening screws.
7. The installation of the data cable [12] to the system control must be according to good professional practice to constitute a correct completion of the sensor technology: A protective cable conduit must be used. (The data cable is not suitable for installing directly in the earth). The end of the data cable that is still unconnected is fitted with a plug connector. This is to be plugged into the appropriate socket [3] of the system control. Diagram 6 makes clear the interrelation:

**Note:**

*The red and the white cable going down to the probe should be straight and smooth to be drawn taught by the weight of the stainless steel probe. The stainless steel probe must hang just above the tank floor.*

The following illustration clarifies the context:

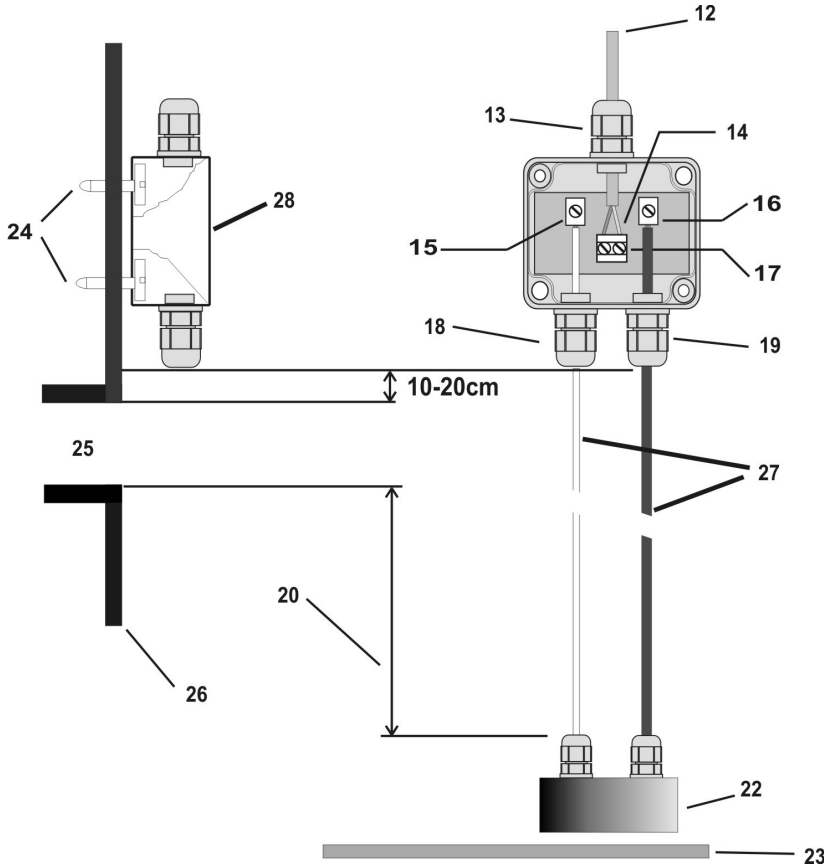

12: Data cable

13: Screw cap 3

14: Connection of the data cable is reverse protected.



- 15: connect white cable here
- 16: connect red cable here
- 17: data cable terminal
- 18: Screw cap 2
- 19: Screw cap 1
- 20: Active measuring length
- 22: Stainless steel probe
- 23: Tank floor
- 24: Screws must be blunted ! (Danger of injury)
- 25: Overflow
- 26: Tank side in dome
- 27: Sensor
- 28: Sensor control box

*Figure 6: Connecting sensors equipment*

#### **2.4 Connection of the data cable to the mains water back-up supply:**

To connect the data cable, join the end prepared with the plug with the appropriate connection socket [3 (in figure 1)] on the mains water – back-up. Before putting the mains water back-up into operation, check and be sure that all electrical connections have been correctly made and that water supply installations are according to regulations and sound practice.

#### **3. Putting into operation and calibration process**

Before the putting the equipment into operation check and be sure that all electrical connections are correctly insulated and all covers are properly closed! Now plug the wall power supply into the mains socket particular to the equipment. In the LCD display there is a run through range of number combinations shown. These are used in the initialization of the equipment. The initialization is completed as soon as the value stops and stays still, i.e. the display shows no further fluctuation. The device now runs with the factory standard settings (measuring cable length of 2 m). Should you have a different measuring cable length then the device must be calibrated. To do this proceed as follows:

### **Calibration procedure:**

#### **1. Fill the tank up to the maximum height.**

*If this is not possible then you should proceed with the alternative as follows:*

- Fill a bucket with water.
- Put in the stainless steel probe with the red and white cables attached in the required measuring lengths completely submersed in the water then continue as from point 2.

#### **2. Press the calibration button. The code "901" is shown in the LCD display.**

#### **3. Release the calibration button and wait until the code "902" is shown in the LCD display.**

#### **4. Now press the calibration button again, short, to save the determined value. The code "903" is shown briefly in the LCD display.**

#### **5. After this wait for a few moments until the display shows 100%.**

#### **Remark:**

*After the code "902" appears the calibration button must be **immediately** pressed, if this is not done then the value will not be saved. If this happens then wait a moment and repeat the process.*

**After the completion of the calibration, the fill level indicator is shown in %, in this case 100% shows.** (Slight variations may be caused by disturbance of the waters surface).

#### **Note:**

*It is possible to re-set the fill level indicator to the factory settings at any time. To do this, pull the plug from the mains and wait for a few seconds. After this press the calibration button and hold it pressed and re-plug the device into the mains. Hold the button pressed until the LCD code "601" is shown in the display.*

### **4. Error messages and fault elimination:**

Directly following switching on and during the operation mode the digital fill level indicator checks the complete system equipment. If an error is diagnosed it will be shown on the LCD display.

**The following messages are possible:**

**602**

The calibration process has not been carried out correctly.

This error code 602 occurs when the calibration button has been held too long. In this case repeat the calibration process.

**701**

Sensor error (the pick up sensor sends no signal)

Start with a check of all the connections of the data cable in the display device and on the pick up sensor. Control also for faulty cables (check for current). Check also the terminals of the sensor pick up electrodes.

If all the cables have been correctly attached and there are no short circuits then the digital fill level indicator must function properly. When the "701" code is still in the display then remove the sensor completely from the tank (the sensor pick up remains attached). The device must now show a value of 0 %. If this is not the case then the sensor is not functioning properly. Please contact the following service number.

A further reason for this signal could be the sensor cable ( [27] in figure 5). In particular the white sensor cable may have absolutely no electrical contact to the water in the tank. Inspect this cable for any damage. It may be necessary to use a magnifying glass to ensure there is no damage or split.

Whether the defect is on the measurement sensor pick-up or the sensor cable is simple to define. Take the sensor cable together with the stainless steel weight completely out of the tank. The measurement sensor pick-up remains connected.

The unit display must now show a value of 0% (there may still be rest moisture). If the unit **now** shows a value of 0%, then the sensor cable is damaged.

If the unit continues to display the error code "701", then the measurement sensor pick-up is defect.

## **5. Manufacturer and service telephone**

Should you have any problems with the equipment, please contact:

A + S Aktuatorik und Sensorik GmbH  
Franz Wienholz Straße 40  
D - 17 291 Prenzlau

Tel.: +49 3984- 80 87 17 / Fax: +49 3984- 80 69 61

E-Mail : info@AS-Prenzlau.de

Internet : www.aktuatorikundsensarik.de.

**We prefer to receive an E-Mail, if you must contact us then be sure to enter the serial number of your controller that begins with “AS”.**  
( *The serial number is found on the name/type label.* )

**6. Disposal of the equipment:**

Old equipment may not be disposed of in the house refuse. It must be brought to the recognised professional recycling depot.  
*Please help – ensure your old electronics come to a separate recycling.*

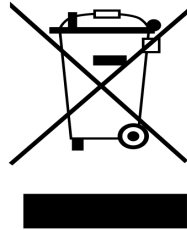

Room for your notes:

Purchase date : .....

Device serial number / Type : AS GN \_ \_ \_ \_ \_

Active measuring length : .....

*Design and specifications are subject to change without notice*  
**January 2013**